



AACER

SPORTS FLOORING

TriPower™ Pad

The next generation in a sports performance pad, Aacer's new TriPower™ Pad provides EN, DIN and PUR certified performance with increased load handling. The TriPower™ Pad's unique, wide stance gives greater response consistency and lower vibration than other pad designs.



see us at
Sweets.com



The mark of responsible forestry

ACCESSORY



TriPower™ Pad



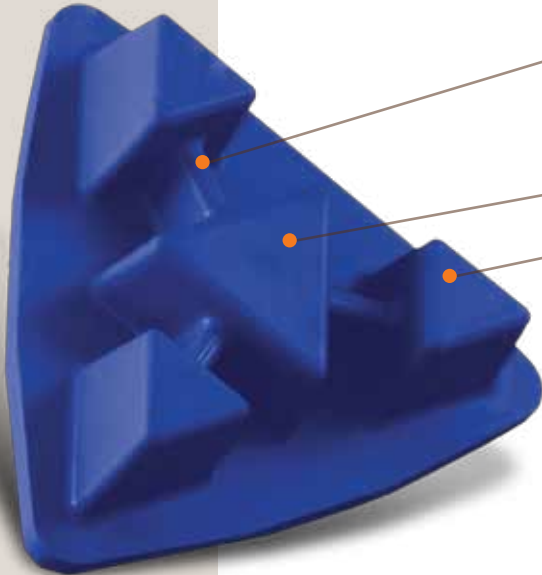



TriPower™ Pad offers superior shock absorption and vibration dampening. The unique blend of EPDM ensures stability and longevity required by high performance floors.

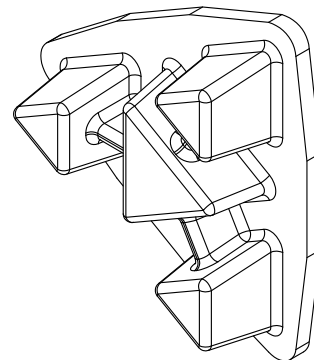
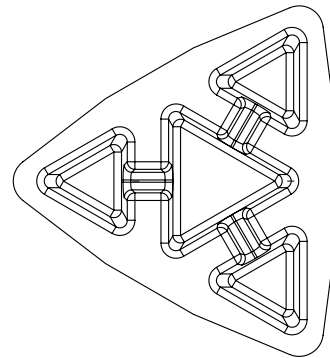

- ① Structural Webs - Cross Linked
 - a. Greater load carrying ability
 - b. Vibration attenuation
 - c. Increased uniformity and consistent response
- ② Stage II Heavy-Duty Load Distribution
- ③ 3 Point Surface Contact Shock Pads - Athletic Resilience

DETAIL DRAWINGS



Composition	EPDM Rubber / recyclable 
Hardness	Shore A
ASTM Durometer	50 - Blue 55 - Black 60 - Orange 70 - Red
Thickness	3/4" (19mm) & 1/2" (12mm)
Triangular Footprint	3 point primary surface contact 1 point secondary load contact
ASTM D412 Tensile PSI	1810
ASTM D412 Elongation	648
Loading	Excellent
Performance Info	     <p> Tested to meet DIN 18032 Part II Tested to meet EN 14904 Tested to meet MFMA PUR standards ASTM 2137 low temperature brittleness, 3 min @ -40 - pass ASTM D395 compression set, 22 hours @ 70c set % -20 </p>
U.S. Patent	#598,8915

Aacer Pad Options

TriPower™ Black  1/2"	TriPower™ Red  3/4"	TriPower™ Orange  3/4"	EcoDIN  7/16"	AacerCush  3/8"	AacerFlex  3/4"
--	--	---	--	--	--