

The following installation details are provided as a supplement to Installation Instructions and Specification for the "AacerFlex" athletic floor system.

1. Start first AacerFlex subfloor panel row and all odd numbered rows with full subfloor panel.
2. As shown below, trim overhanging long edge and end edge of starting panel in first row to remove extending upper plywood sections.
3. Align panel in starting corner by providing 1-1/2" expansion spacing between subfloor panel edges and perimeter walls, and all vertical obstructions.

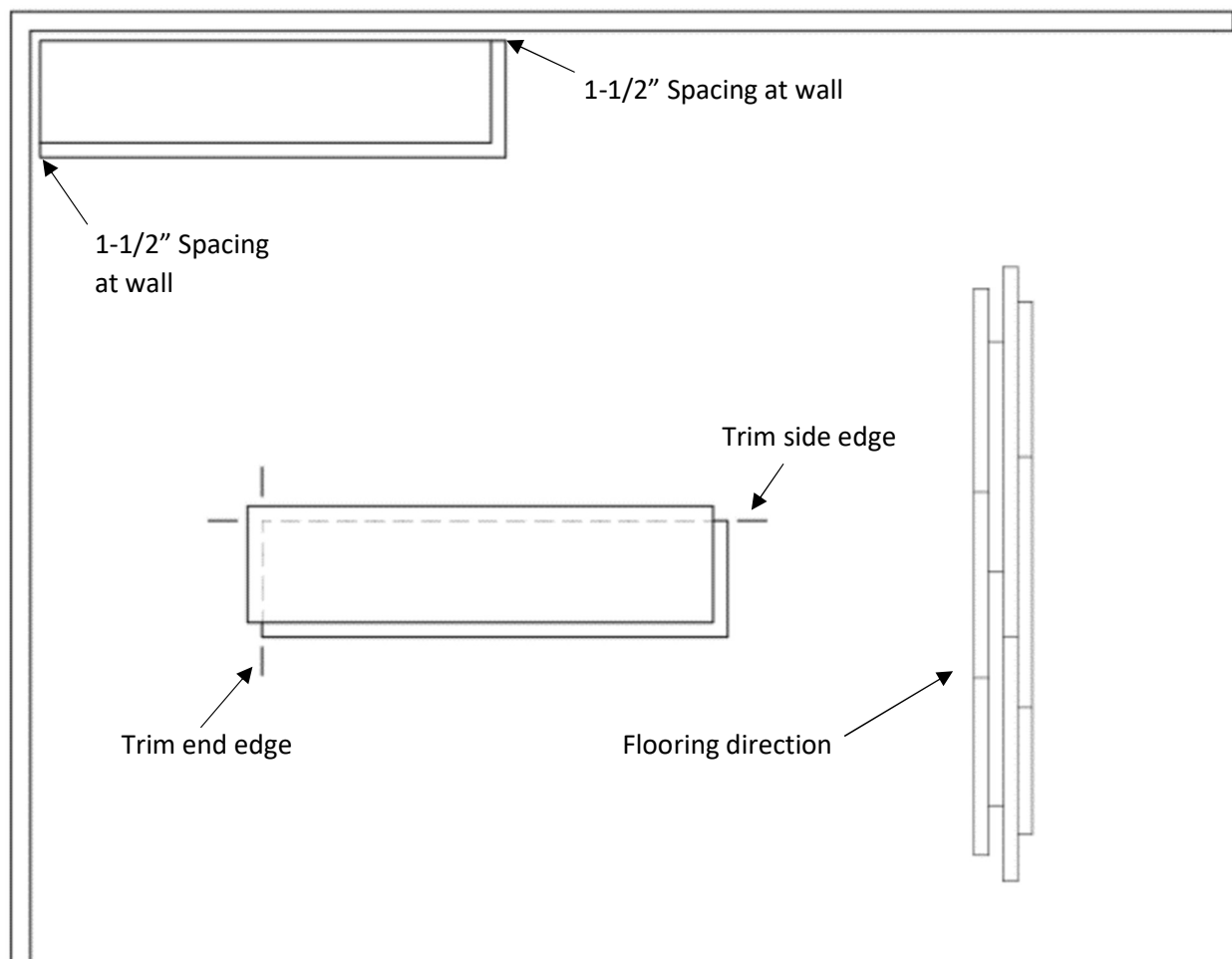

4. Complete first row along wall as shown below by adding full subfloor panels after removing overlapping side edge. Soundly secure each overlapping panel with a minimum of four 1" subfloor staples.
5. Provide 1/4" spacing between ends of adjacent panels and 1-1/2" spacing between subfloor panels and wall, and vertical obstructions.

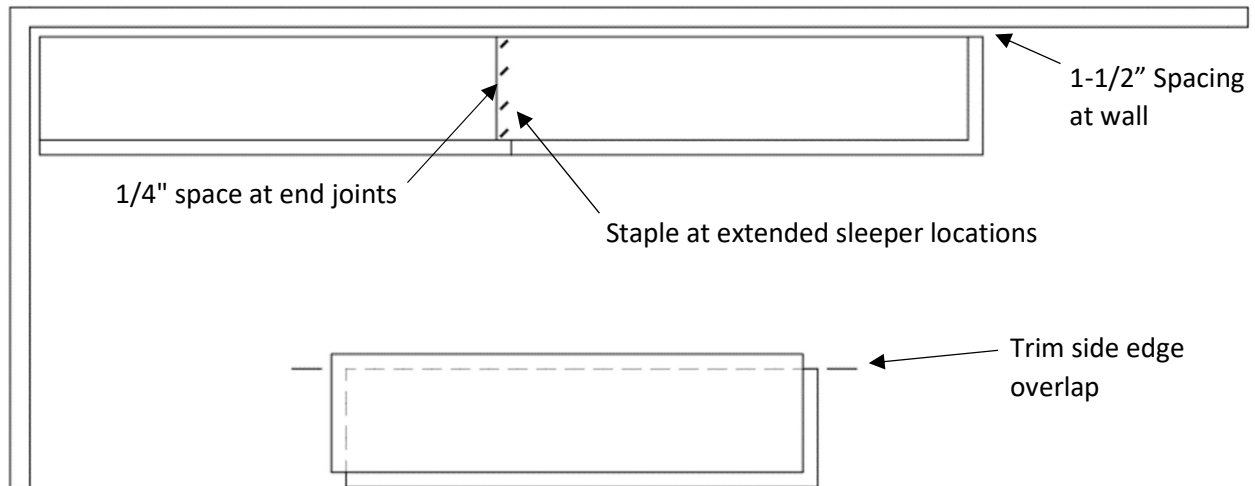

6. Start second panel row and all even numbered rows as shown below by cross cutting full panel 48" measured off of bottom subfloor layer. Offset side edge 1/4" from adjacent subfloor panel and attach overlapping side edge to adjacent panel with 1" subfloor staples applied 12" on center including at ends.

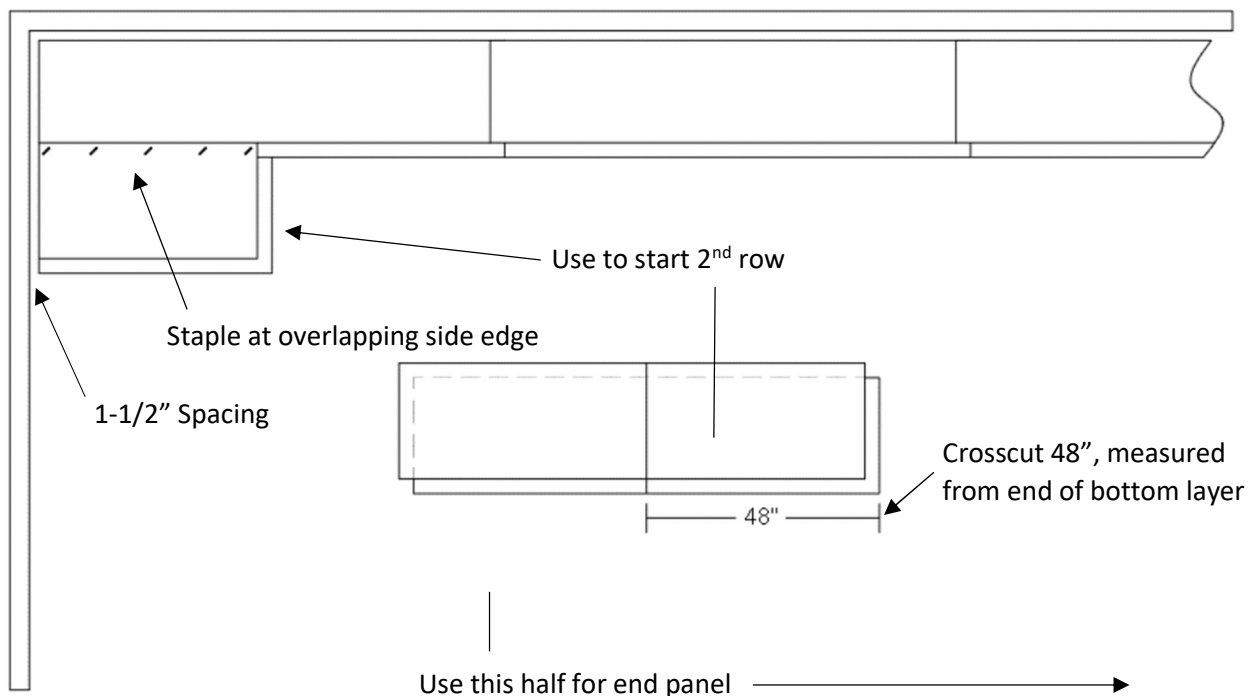

7. Continue second panel row with full subfloor panels with panel edges offset 1/4" from adjacent panels. Fasten panel side edge and end edge as illustrated below with minimum four fasteners at end joints and spaced 12" on center at side joints.

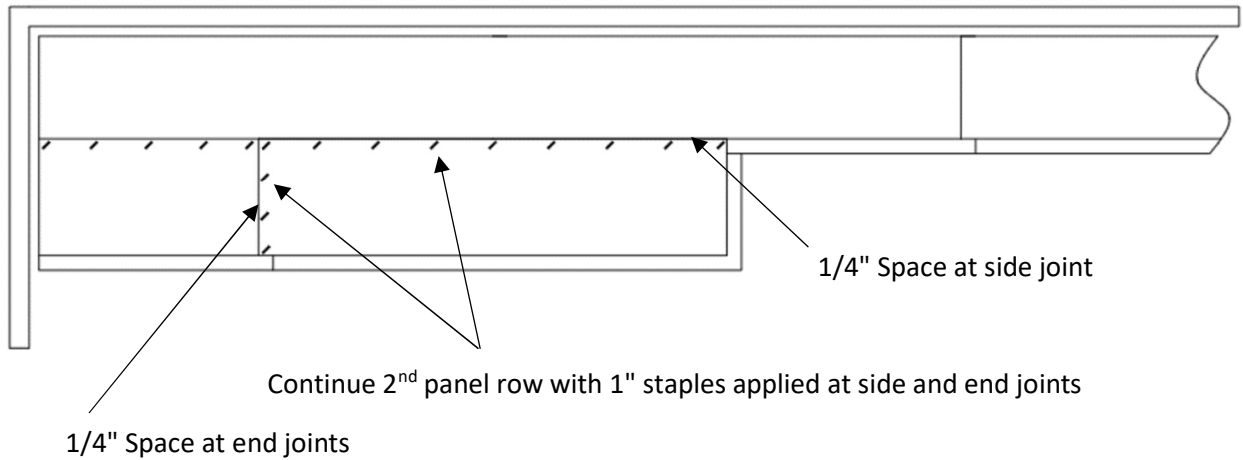

8. Start remaining odd numbered rows as shown below by removing overhanging end edge. Space panel 1-1/2" from wall and overlap and attach side joint as previously described, with 1/4" spacing from adjacent panels.

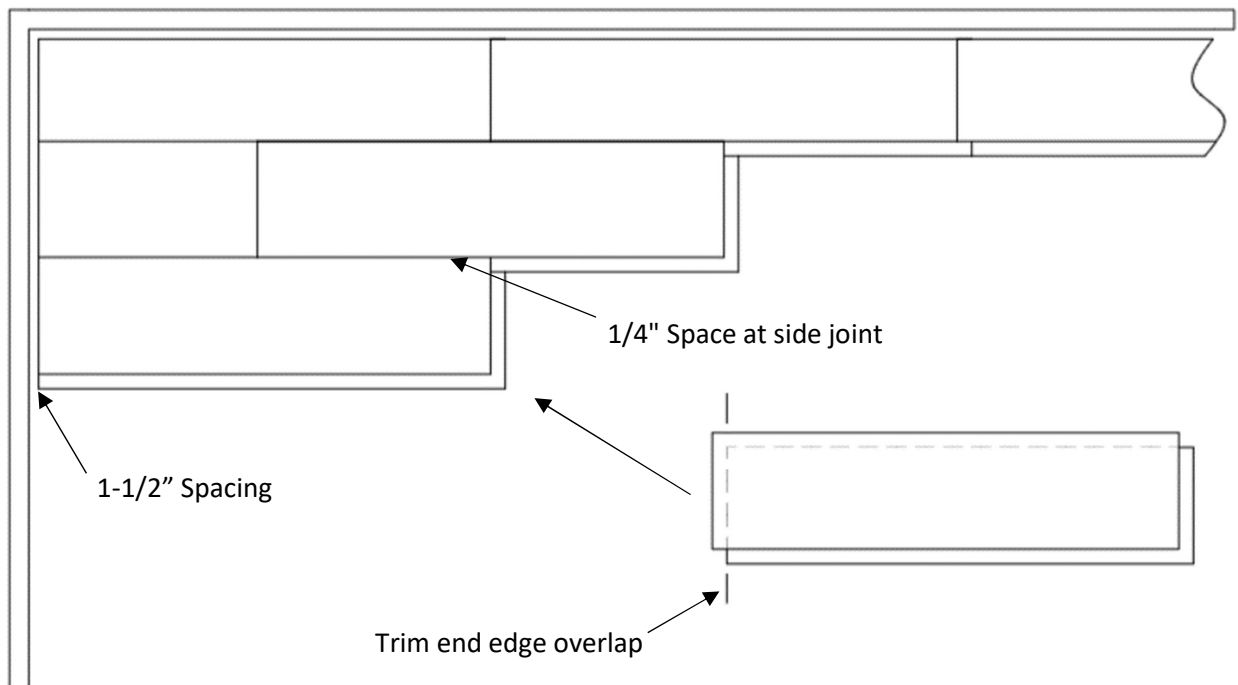

1. Continue installation by alternating full and half panels when starting each row, with panels trimmed as previously described. Complete each row with full panels, and complete with partial panels to a space of 1-1/2" from end wall.
2. Provide 1/2" thick solid blocking sections below subfloor where required such as at closed bleacher locations, below portable goals, and doorways.

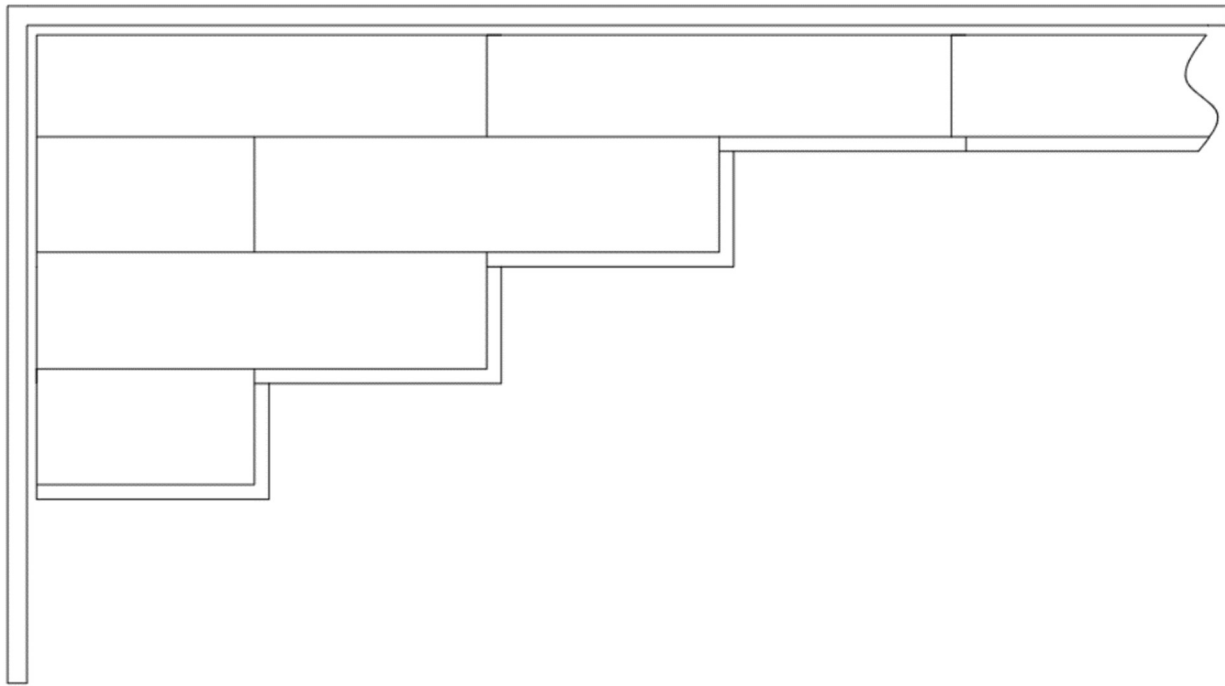

- To reduce waste, partial panels from completion of previous rows can be acceptably used to start panel rows provided that panels are minimum 16" in length and provided that panel ends are offset by a minimum of 12" from panel ends of adjacent rows.