

The following installation details are provided as a supplement to Installation Instructions and Specification for the “AcerFlex VLP” athletic floor system.

After placing foam blanket layer with all edges abutted tightly, install subfloor panels per the following installation instructions.

1. As shown below, install trimmed AcerFlex subfloor panel diagonally to finished flooring with lower subfloor extending outward.
2. Align panel in starting corner by providing 1-1/2” expansion spacing between subfloor panel edges and perimeter walls, and all vertical obstructions.

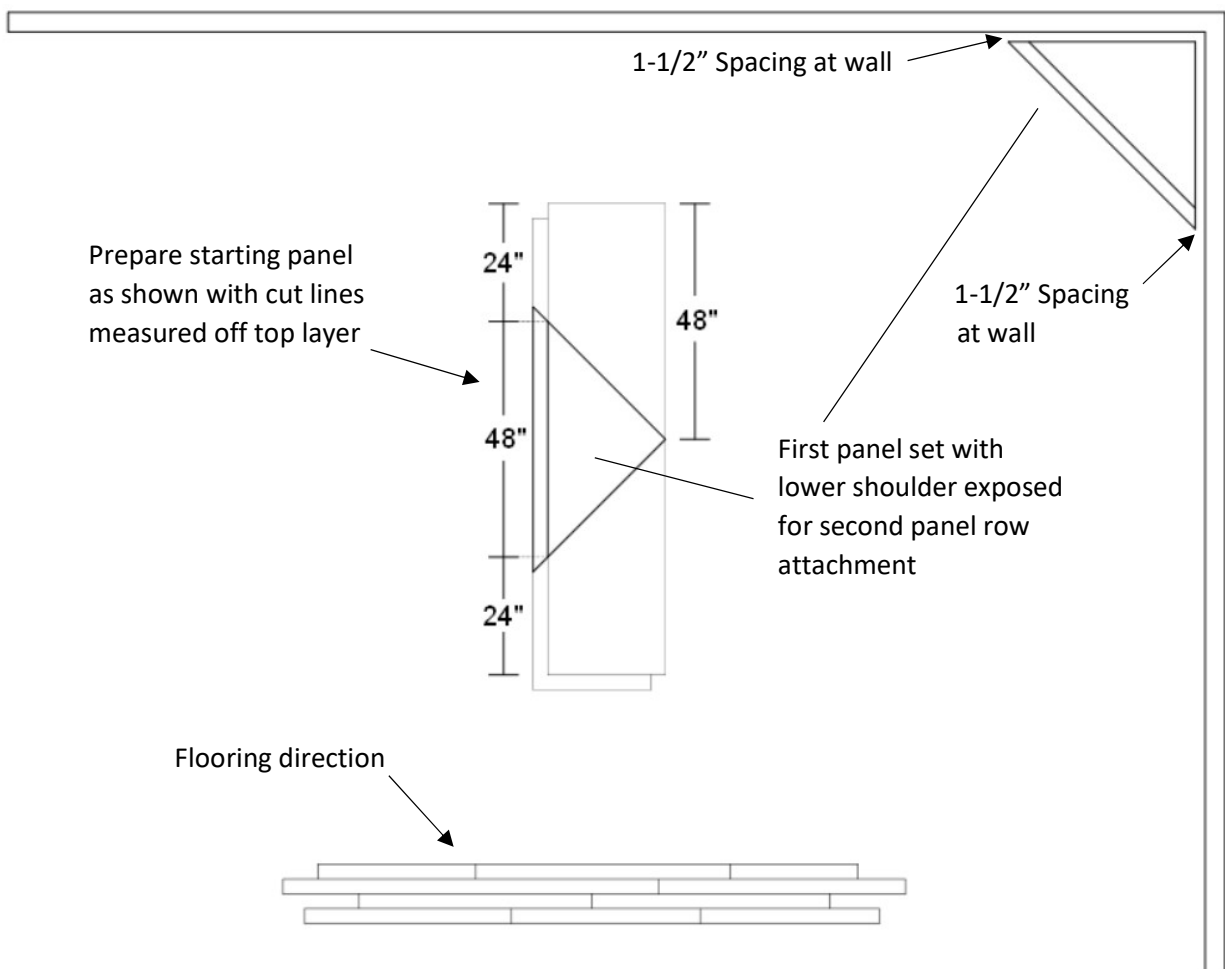

3. Align second subfloor panel as shown below while maintaining nominal 1/4" spacing between side joints.
4. Provide 1-1/2" to 2" expansion spacing between subfloor panel edges and perimeter walls, and all vertical obstructions.
5. Attach overlapping side edge of upper subfloor panel to lower subfloor with 3/4" staples applied nominally 12" on center.

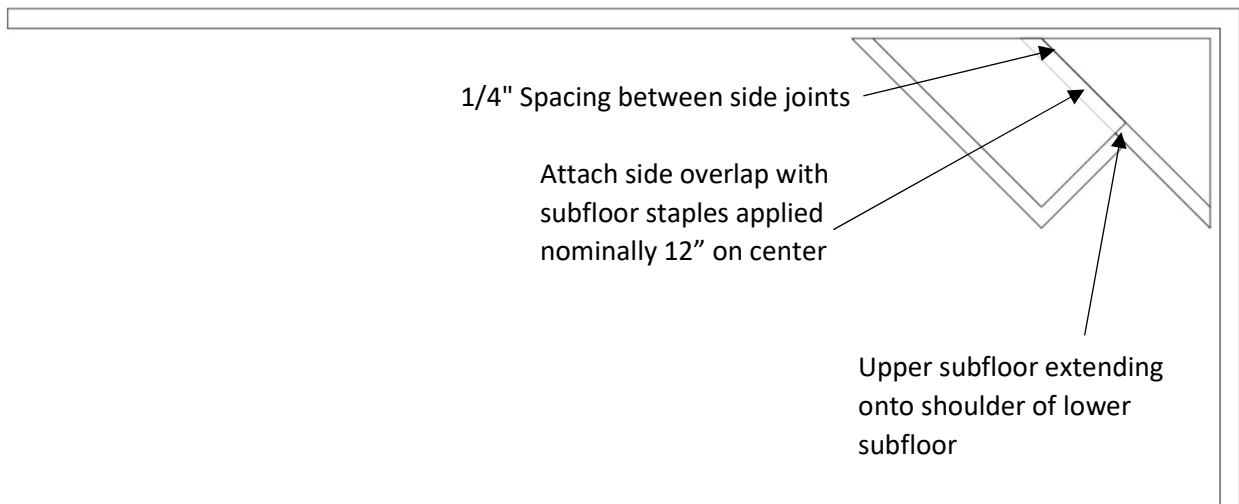

6. Complete second row as shown below while maintaining nominal 1/4" spacing between side and end joints and 1-1/2" to 2" expansion spacing at wall.
7. Fasten panels with staples applied nominally 6" on center at end overlaps and nominally 12" on center at side overlaps.

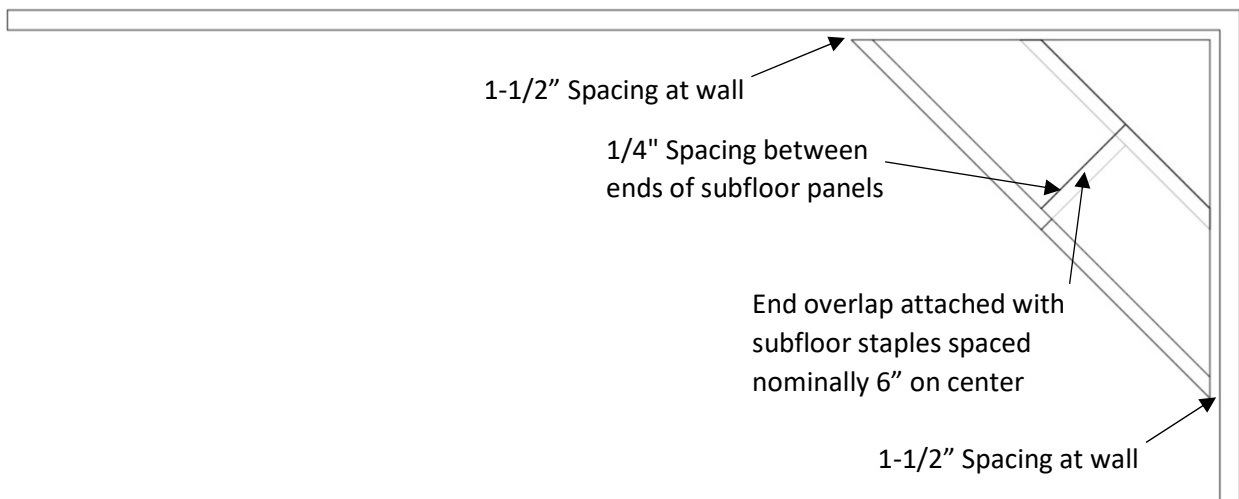

8. Offset panel ends in each row by 4' from panel ends in adjacent rows as shown below.

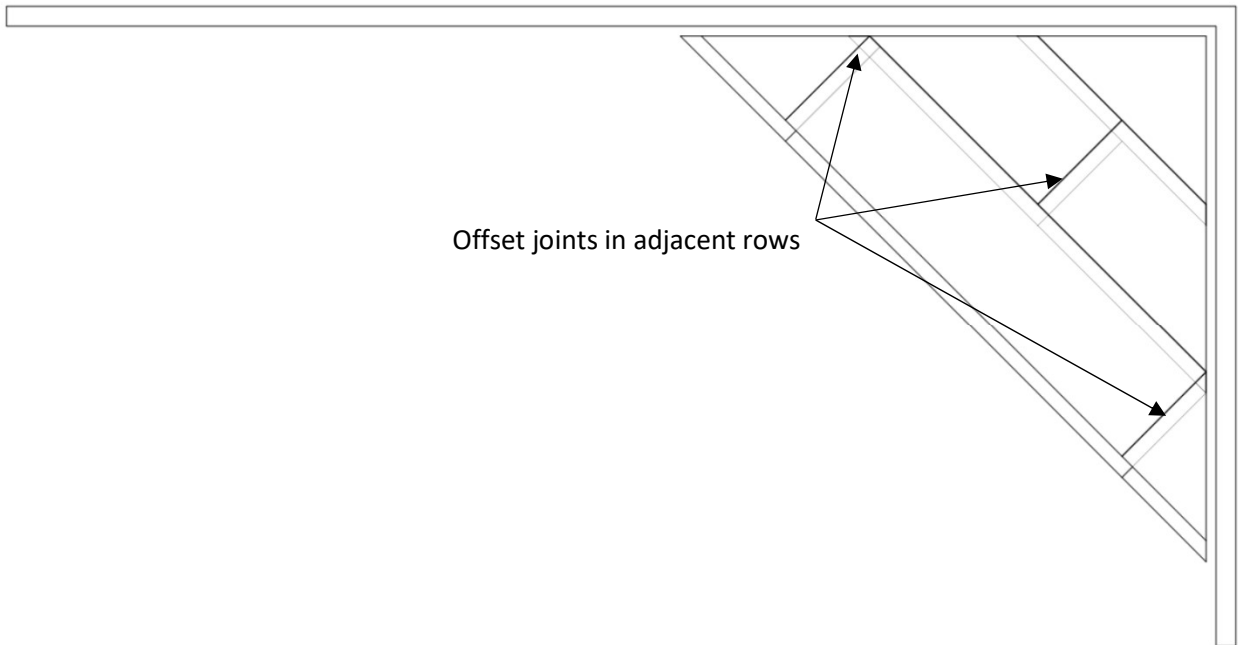

9. Continue additional subfloor panel rows as previously described by staggering end joints in each adjacent row. Maintain 1/4" spacing between subfloor edges and provide 1-1/2" to 2" spacing at walls and all vertical obstructions.

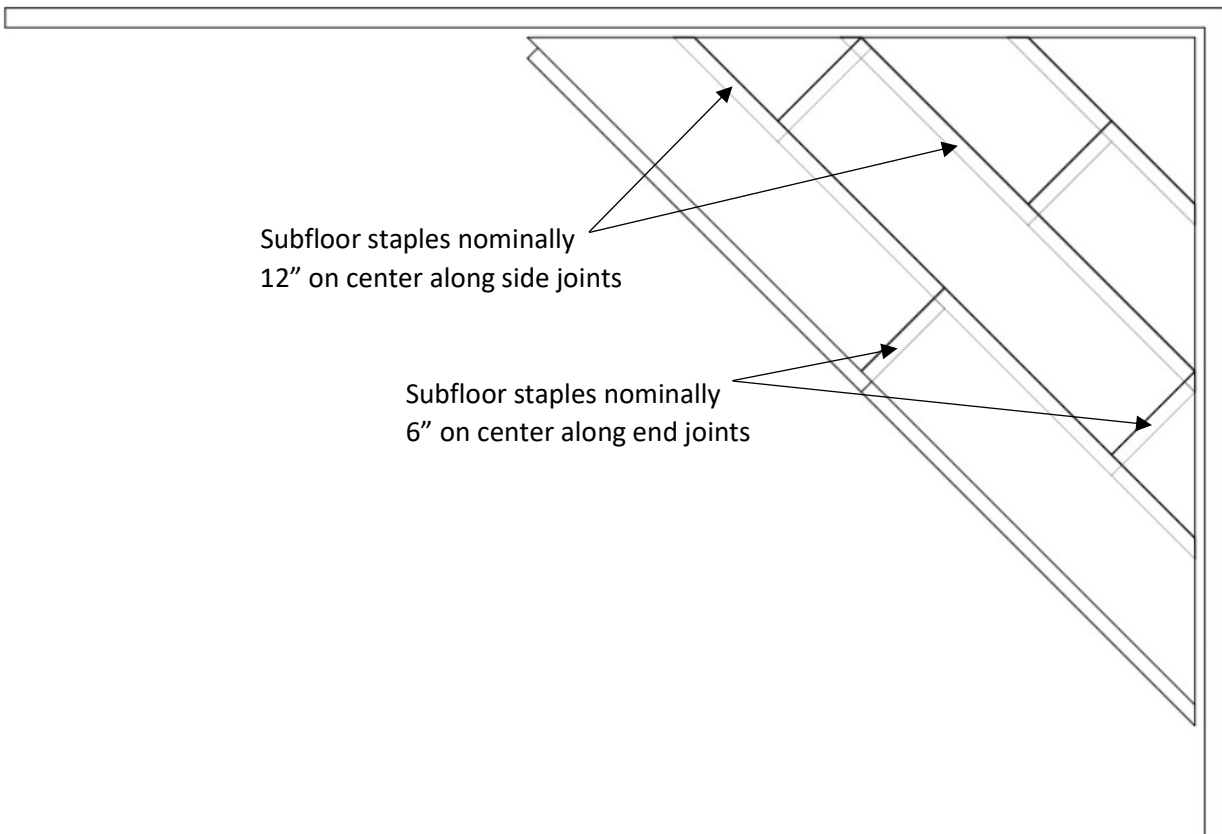

10. Cut ends from starting side and end walls can provide angles suitable for beginning and completing rows adjacent to other side and end wall locations.
11. End joints in adjacent rows can be acceptably offset by minimum 16" to allow for limited waste without compromising floor system integrity.
12. **IMPORTANT:** This installation guide is not a substitute for all other "AacerFlex VLP" installation and specification instructions.

END

24 REV A