

POWERPLAY EDGE
General Installation Detail

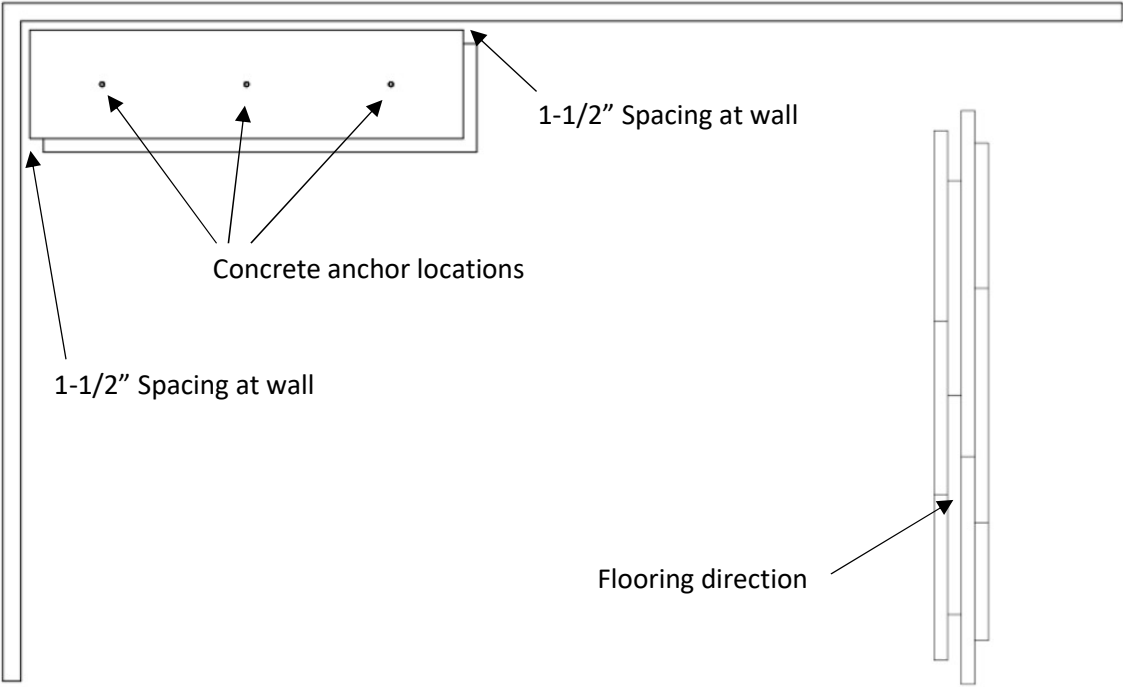

The following installation guide is provided as a supplement to Installation Instructions and Specification for the “PowerPlay Edge” athletic floor system, all of which are to be followed to assure proper installation.

1. Align first subfloor panel in starting corner as shown below by providing 1-1/2” expansion spacing between subfloor panel edges and perimeter walls, and all vertical obstructions.
2. Refer to concrete anchorage pin, sleeve and washer assembly as described at the end of page 4. Drill concrete substrate with 1/4" masonry bit at each anchor location and drive anchorage pins only until snug, do not overdrive.



3. NOTE: Always inspect underside of cut panels to assure sound support at, or near (within 6”), cut ends.

- Complete first row as shown below with overlapping nailers resting on shoulder of previous panel by adding full subfloor panels. Tightly secure each overlapping panel end with four 3/4" staples.
- Provide 1/4" spacing between ends of adjacent panels, and 1-1/2" spacing between subfloor panels and walls, and vertical obstructions.

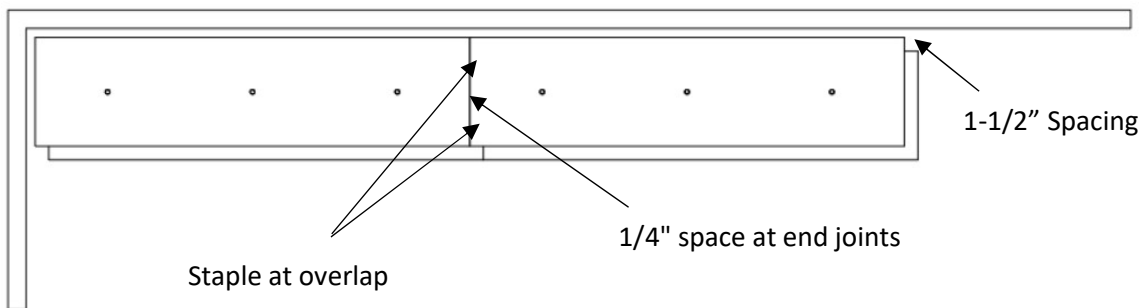

- Start second panel row and even numbered rows as shown below by cross cutting full panel 48". Space side edge of upper subfloor panel 1/4" from side edge of first panel row and allow 1-1/2" spacing between end of panel and wall. Attach overlapping side edges of adjacent panels with 3/4" staples nominally 12" on center. Secure panel to concrete as previously described.

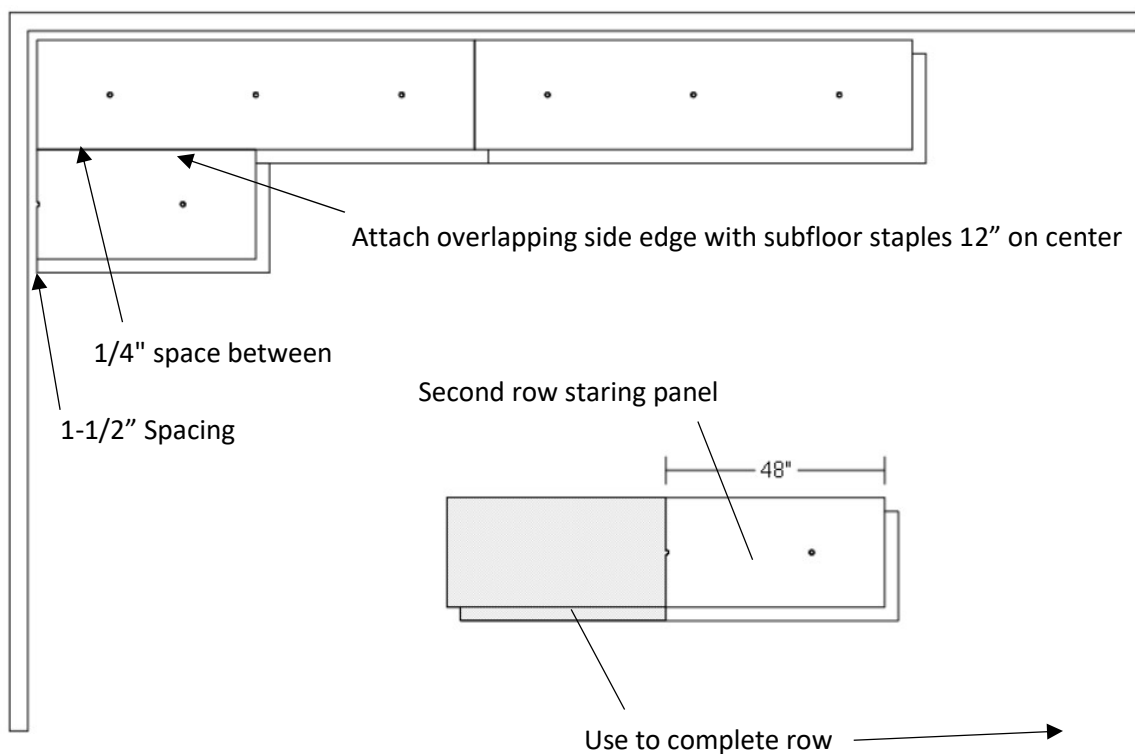

7. Complete second row with full subfloor panels by maintaining 1/4" spacing between panel side and end edges. Attach side and end overlaps as previously described.

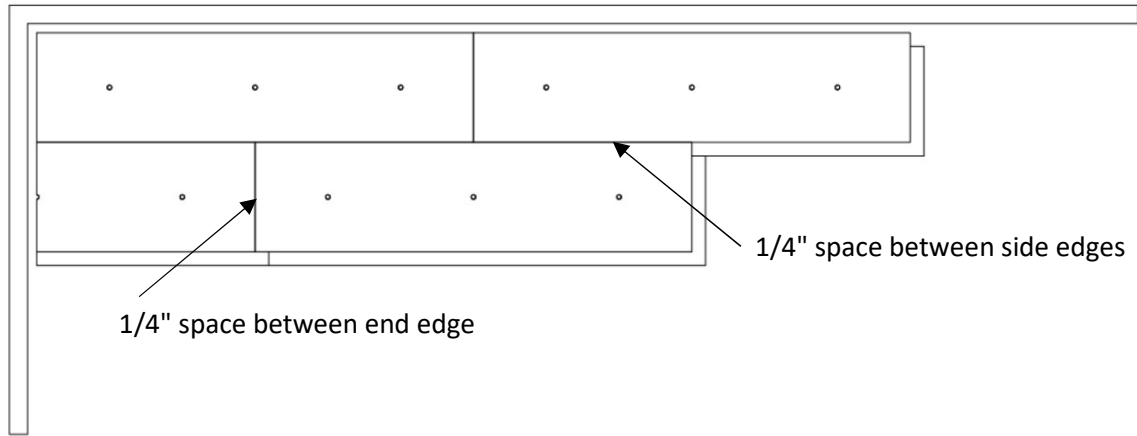

8. Continue subfloor pattern as shown below by starting third row and all odd numbered rows with full panels. Provide all spacing and attachments as previously described.

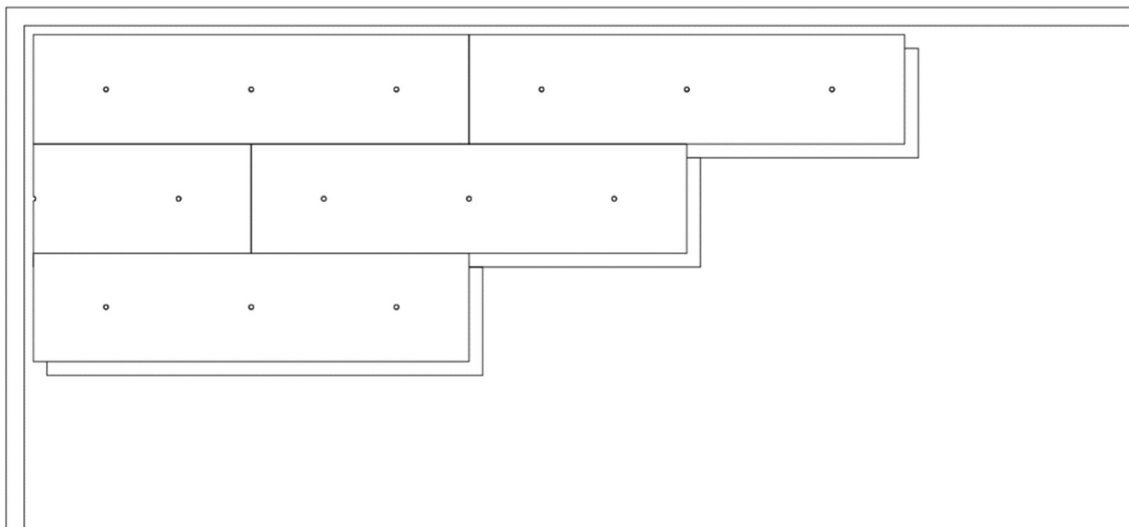

9. Complete subfloor as illustrated on following page by
 - correctly staggering panel ends of adjacent rows,
 - providing 1/4" spacing between panel rows,
 - allowing 1-1/2" spacing at walls and at all vertical obstructions,
 - providing 1/4" spacing between panel ends,
 - soundly attaching subfloor overlaps to previous panels,
 - and securing to concrete at each anchor location.

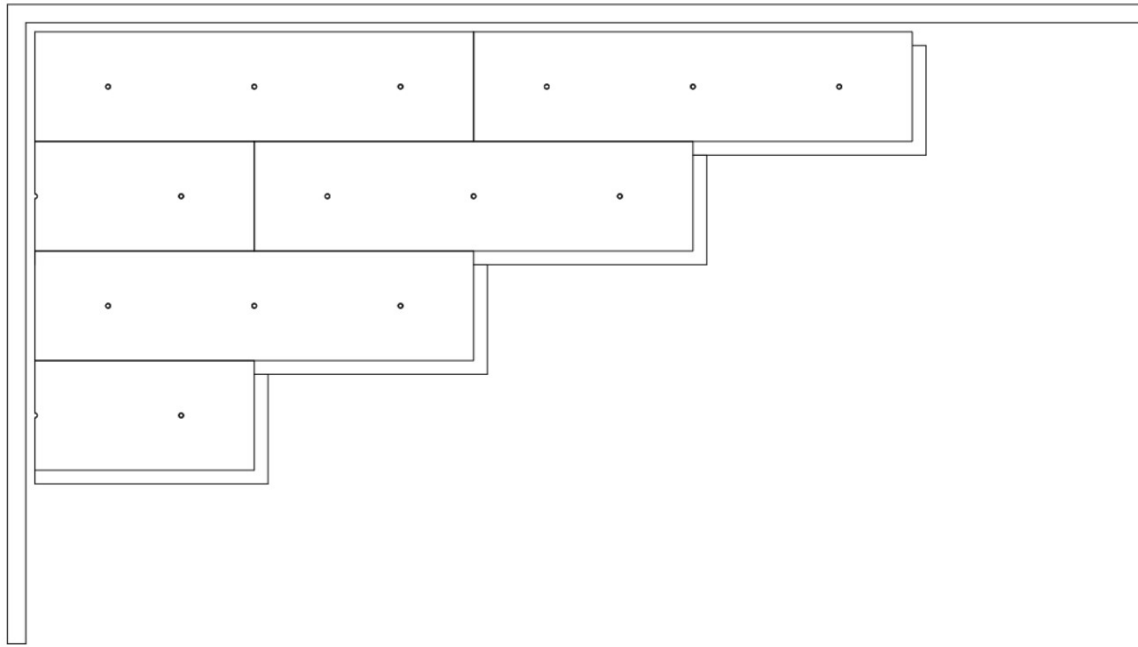

- To reduce waste, partial panels from completion of previous rows can be acceptably used to start panel rows provided that panels are minimum 16" in length and provided that panel ends and anchors are offset by a minimum of 12" from panel ends of adjacent rows.

CONCRETE ANCHOR PIN, SLEEVE, AND WASHER ASSEMBLY

