

# Programme III Stage

## FIXED RESILIENT SYSTEMS

Programme III subfloor panels are specifically designed to add resilient pad support as active impacts increase, and provide a manner to limit pressure on elastic material and subfloor components when significant heavy loads are applied. The combination of offering high shock absorption for solo and multiple performers, along with the ability to address heavy associated weights, makes Programme III an excellent consideration for performance floor applications.

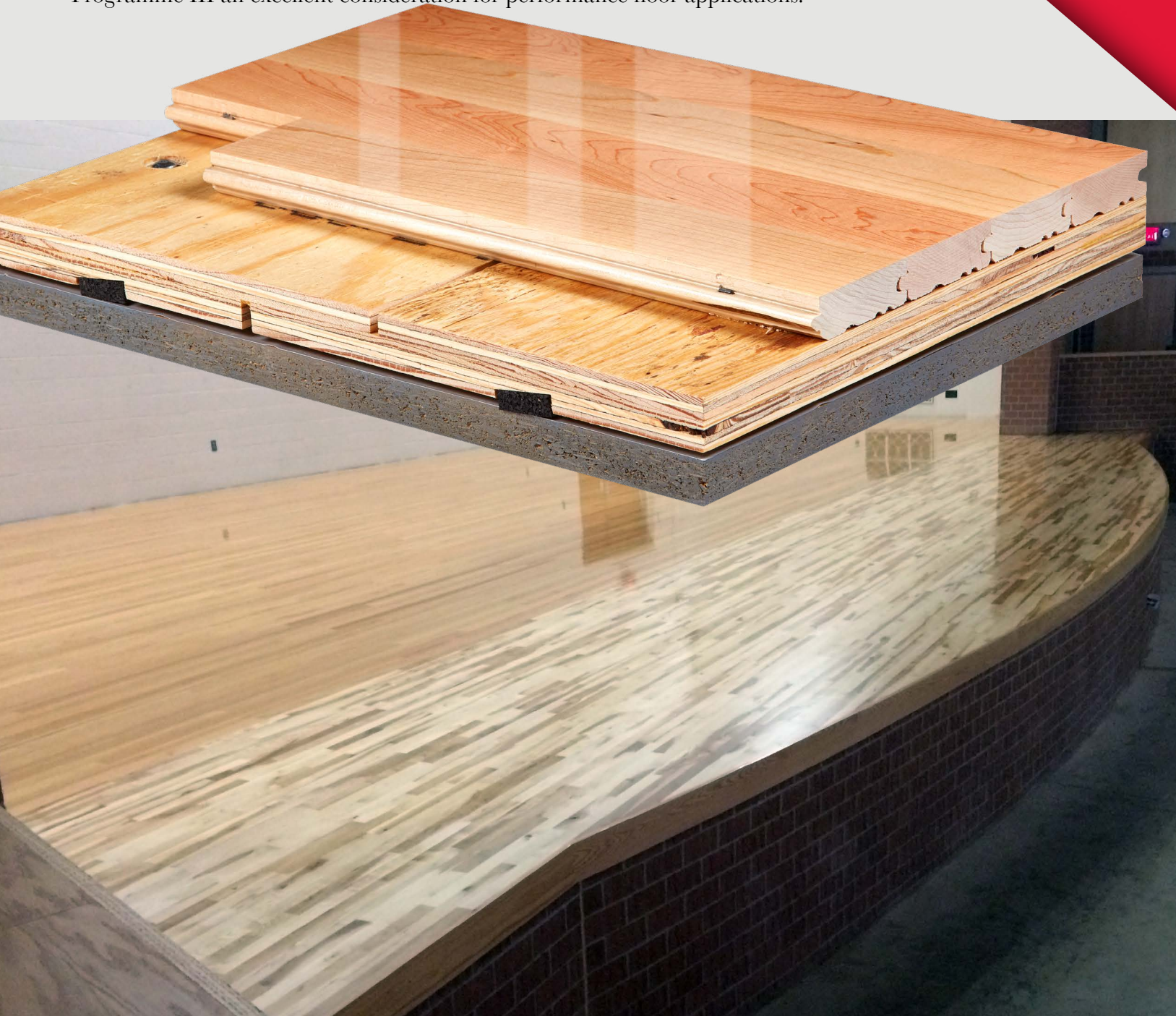

# Programme III Stage

## WALLBASE Maple Floor Surface

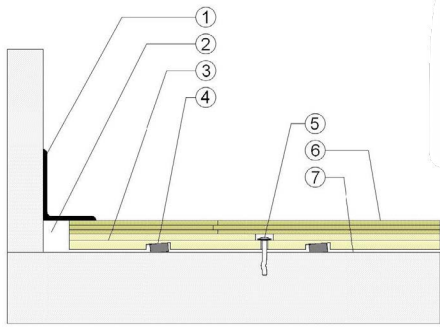

1. 3" x 4" (76mm x 101mm) Vent Cove Base
2. 1-1/2" (38mm) Min. Expansion Space
3. Programme III Subfloor Panel
4. Recessed Resilient ECO Pad
5. Concrete Anchor Pin Assembly
6. 25/32" (20mm) MFMA Maple Flooring
7. Vapor Retarder

## THRESHOLD Maple Floor Surface

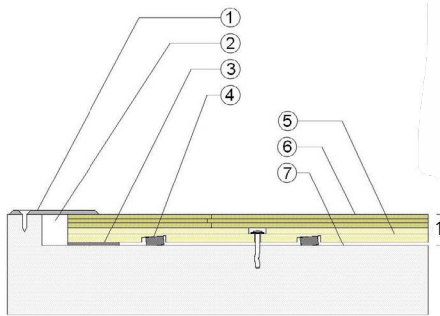

1. 1/4" (6mm) Aluminum Threshold
2. 1-1/2" (38mm) Min. Expansion Space
3. Solid Blocking at Doorway
4. Recessed Resilient ECO Pad
5. Programme III Subfloor Panel
6. 25/32" (20mm) MFMA Maple Flooring
7. Vapor Retarder

## HARDBOARD Panel Floor Surface

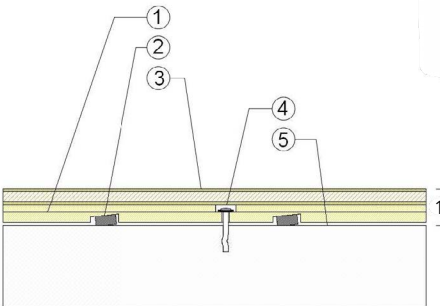

1. Programme III Subfloor Panel
2. Recessed Resilient ECO Pad
3. Hardboard Faced Laminate Panel
4. Concrete Anchor Pin Assembly
5. Vapor Retarder

## HARDBOARD Layer Floor Surface

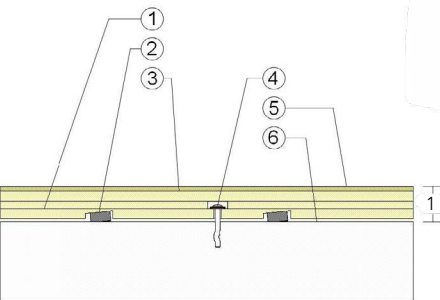

1. Programme III Subfloor Panel
2. Recessed Resilient ECO Pad
3. 15/32" (12mm) Added Plywood Layer
4. Concrete Anchor Pin Assembly
5. 1/4" (6mm) Hardboard Surface Layer
6. Vapor Retarder

### Anchorage

Collared Steel Drive Pin

### Green Status and LEED Contributors



- FSC® Certified Maple - MR
- FSC® Certified Subfloor Components - MR
- Environmental Quality - EQ
- Regional Materials - MR

### Resilience

1/2" (12mm) ECO Pad

### Slab Depression

- 25/32" (20mm) Flooring - 1-3/4" (44mm)

### Floor Surface Options

- 25/32" (20mm) Maple Flooring
- 25/32" (20mm) Red Oak Flooring
- Hardboard Laminate Panel
- Hardboard Surface Layer

### Optional Programme Systems

Programme I Stage  
Programme II Stage

### Subfloor Construction

Pre-manufactured Panels

### System Type

Fixed Resilient

### Testing Laboratory Partners



*It is the policy of Aacer Flooring to continuously improve its line of products. Therefore, Aacer Flooring reserves the right to change, modify or discontinue systems, specifications and accessories of all products at any time without notice or obligation to purchaser.*



see us at  
**Sweets.com**

